

**PRODUCT SPECIFICATIONS**

Halsey Taylor Endura II™ Outdoor HydroBoost® Upper Bottle Filling Station Bi-Level with Pet Station Non-Filtered Non-Refrigerated. Features shall include 316 Stainless, Heavy Duty Vandal Resistant, Laminar Flow, Pet Fountain. Furnished with Vandal Resistant bubbler. Product shall be Floor Mount/Freestanding, for Outdoor applications, serving 2 station(s). Unit shall be lead-free design which is certified to NSF/ANSI 61 & 372 (lead free) and meets Federal and State low-lead requirements.

<b>Special Features:</b>	316 Stainless, Heavy Duty Vandal Resistant, Laminar Flow, Pet Fountain
<b>Finish:</b>	Beige (BGE), Black (BK), Blue (BLU), Brown (BRN), Evergreen (EVG), Gray (GRY), Orange (ORN), Powder Coat (12 Color Options), Purple (PUR), Red (RED), Terracotta (TER), White (WHT), Yellow (YLW)
<b>Power:</b>	No Electrical Required
<b>Bubbler Style:</b>	Vandal Resistant
<b>Mounting Type:</b>	Floor Mount/Freestanding
<b>Chilling Capacity:</b>	Non-refrigerated
<b>Approx. Shipping Weight:</b>	205 lbs.
<b>Installation Location:</b>	Outdoor
<b>No. of Stations Served:</b>	2

\*\*When used in non-temperature controlled environments, unit(s) must be adequately winterized and/or protected from extreme heat to prevent damage where climates dictate.

**Special Note: Bottle Filler Stations 1 (Upper), Bubbler Stations 1 (Low), Choose from 12 color options**

- Laminar flow provides clean fill with minimal splash.
- Base material constructed from marine-grade 316 stainless steel provides the ultimate corrosion protection from even the most corrosive elements.
- Pet Fountain: Features slow drainage for easy drinking.



**Ships in one box.**

**AMERICAN PRIDE. A LIFETIME TRADITION.** Like your family, the Elkay family has values and traditions that endure. For almost a century, Elkay has been a family-owned and operated company, providing thousands of jobs that support our families and communities.



**PRODUCT COMPLIANCE**

- ADA & ICC A117.1
- ASME A112.19.3/CSA B45.4
- Buy American Act
- GreenSpec®
- NSF/ANSI 61 & 372 (lead free)



Complies with ADA & ICC A117.1 accessibility requirements when installed according to the requirements outlined in these standards. Installation may require additional components and/or construction features to be fully compliant. Consult the local Authority Having Jurisdiction if necessary.

[Installation Instructions \(PDF\)](#)

**Warranty pertains to drinking water applications only. Non-drinking water applications are not covered under warranty.**

[Warranty \(PDF\)](#)

PART: \_\_\_\_\_ QTY: \_\_\_\_\_

PROJECT: \_\_\_\_\_



CONTACT: \_\_\_\_\_

DATE: \_\_\_\_\_

NOTES: \_\_\_\_\_

APPROVAL: \_\_\_\_\_

*In keeping with our policy of continuing product improvement, Halsey Taylor reserves the right to change product specifications without notice. Please visit Halseytaylor.com for the most current version of Halsey Taylor product specification sheets. This specification describes a Halsey Taylor product with design, quality, and functional benefits to the user. When making a comparison of other producers' offerings, be certain these features are not overlooked.*

Optional Accessories		
<a href="#">4471LHB</a>	Locking Hose Bib <a href="#">Spec Sheet (PDF)</a>	
<a href="#">97890C</a>	Accessory - Direct Bury Adaptor <a href="#">Spec Sheet (PDF)</a>	

*In keeping with our policy of continuing product improvement, Halsey Taylor reserves the right to change product specifications without notice. Please visit [Halseytaylor.com](http://Halseytaylor.com) for the most current version of Halsey Taylor product specification sheets. This specification describes a Halsey Taylor product with design, quality, and functional benefits to the user. When making a comparison of other producers' offerings, be certain these features are not overlooked.*

**MOUNTING INSTRUCTIONS and PLUMBING CONNECTIONS**

Provide solid, well-drained surface to mount pedestal fountain (concrete pad recommended). Mount on a smooth, flat, finished surface with adequate support (300 lb. load minimum). Secure unit with (8) 3/8" minimum fasteners (not included). Refer to rough-in. Should be attached firmly to mounting surface in order to secure unit.

Modified low stream height bubbler for pet fountain.

Locate and install plumbing through ground as required.

**NOTE:** Unit is not furnished with service valve.

Position pedestal over plumbing and secure base to fasteners. Remove access panels and connect supply and water lines. Turn on water supply and check for leaks. Reassemble access panels to pedestal.

**Trap and service stop not included.**

**OPERATING PRESSURES:**  
Supply water 20 – 105 psi maximum

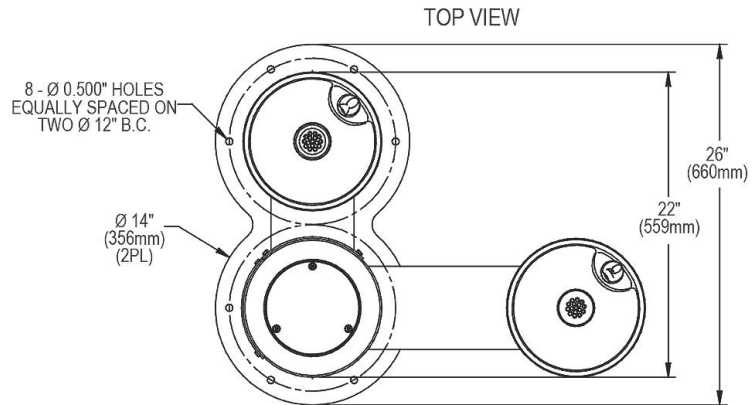

**FRONT & SIDE VIEWS**

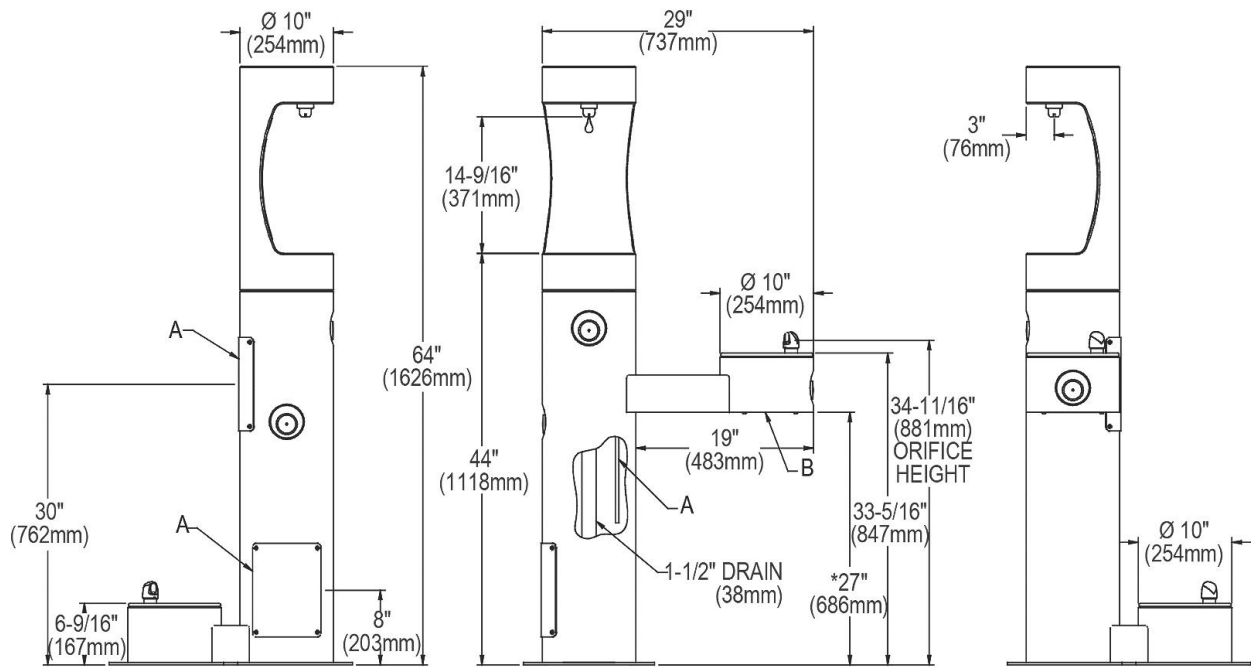

A = 3/8" O.D. Unplated copper tube connect. Shut off valve by others.  
B = Access panel(8" x 10").  
C = Removable bottom cover.

\* ADA Requirement

*In keeping with our policy of continuing product improvement, Halsey Taylor reserves the right to change product specifications without notice. Please visit [Halseytaylor.com](http://Halseytaylor.com) for the most current version of Halsey Taylor product specification sheets. This specification describes a Halsey Taylor product with design, quality, and functional benefits to the user. When making a comparison of other producers' offerings, be certain these features are not overlooked.*